

Internetworking Devices

- an internet = a collection of connected networks which share a common set of rules for communication
 - reminder: **the Internet** = connected set of networks which all use IP
- usually, additional devices are needed:
 - a broadcast LAN may need to extend further than its standard allows – use **repeaters** (also called signal regenerators)
 - the number of nodes required on the network may be too high, so the network may have to be subdivided – use **bridges**
 - two or more networks may have to be connected together – use **routers** (if the networks use the same Network layer protocol) or **gateways** (if the networks use different protocol stacks)
- warning: terminology is not universally agreed on (especially by equipment manufacturers and vendors :^)
- e.g. confusion between functionality of bridges vs. routers...

1

Internetworking Devices (cont.)

- each type of internetworking device interacts with protocols at different layers of the OSI model

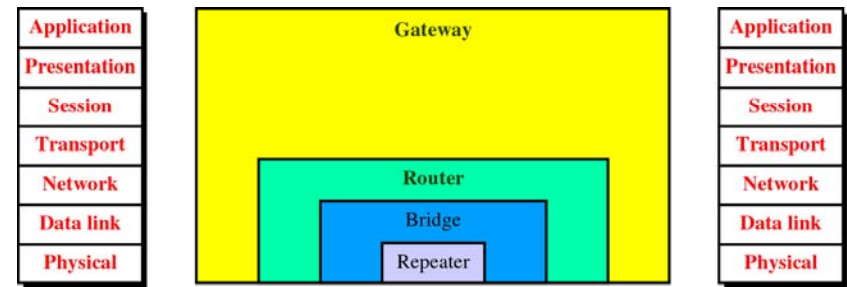

- repeater – active only at the Physical layer
- bridge – most active at the Datalink layer
- router – links separate but similar LANs ⇒ most active at the Network layer
- gateway – provides “translation” service between incompatible LANs or applications ⇒ active in all layers
 - NOTE: each of these devices also operates in all layers **below** the one in which it is most active

2

Internetworking Devices: Repeater

- an electronic device which regenerates (“cleans up”) incoming signals
 - allows the physical reach of a network to be extended

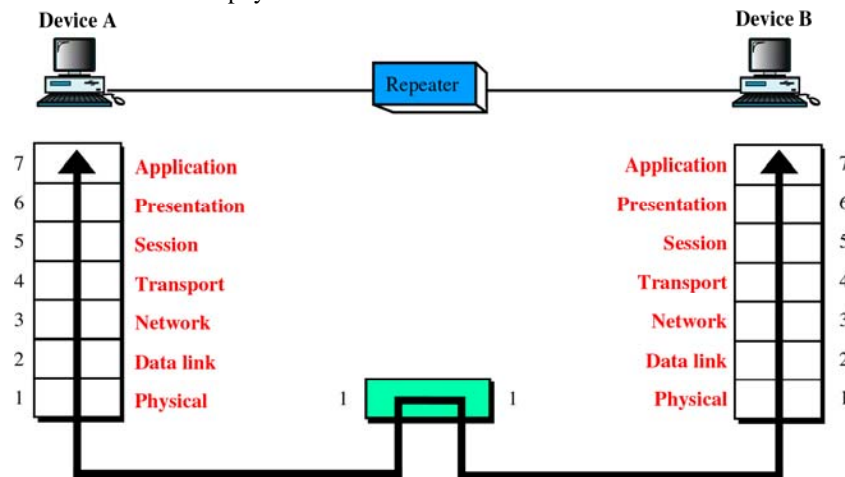

3

Internetworking Devices: Repeater (cont.)

- a repeater **does not filter** frames, e.g. A’s Frame to B also received by C & D

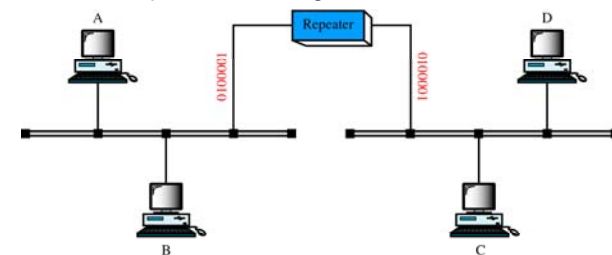

- a repeater copies and “refreshes” incoming bits – it **does not amplify** the signal

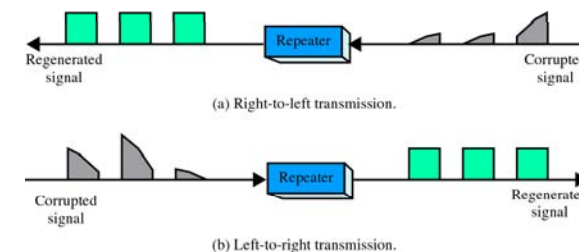

4

Internetworking Devices: Bridge

- operates in both the Physical and Datalink layers
 - a bridge knows the physical addresses of the connected nodes

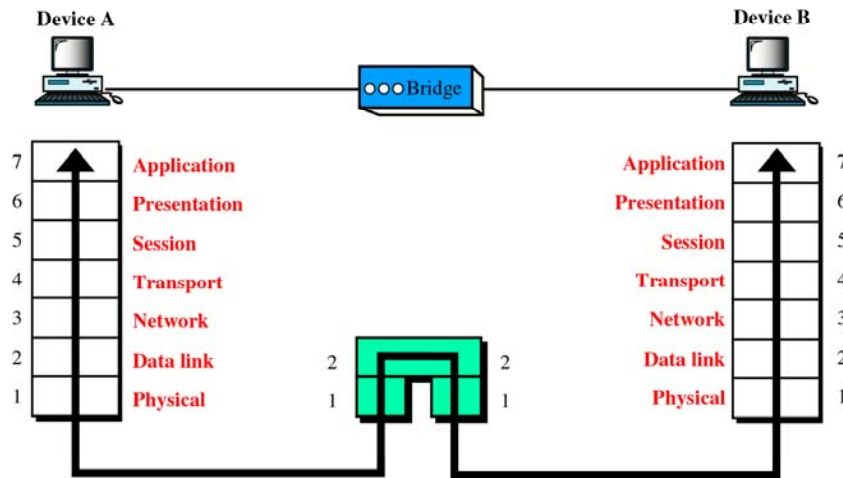

5

Internetworking Devices: Bridge (cont.)

- a bridge can divide a large network into smaller segments, or relay Frames between 2 originally unconnected LANs:

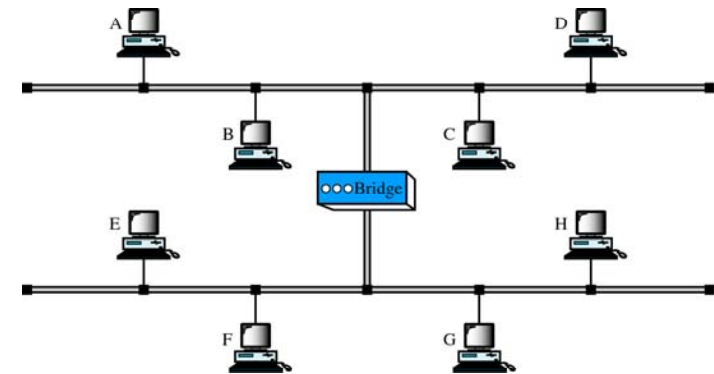

- unlike a repeater, a bridge contains logic which allows it to keep traffic for each segment separate ⇒ **bridge can filter traffic**
 - helps in controlling traffic congestion, isolating problems, security...

6

Internetworking Devices: Bridge traffic filtering

- when a Frame arrives, the bridge not only regenerates the signal but also checks the destination address, and only forwards the Frame to the segment to which this address belongs:

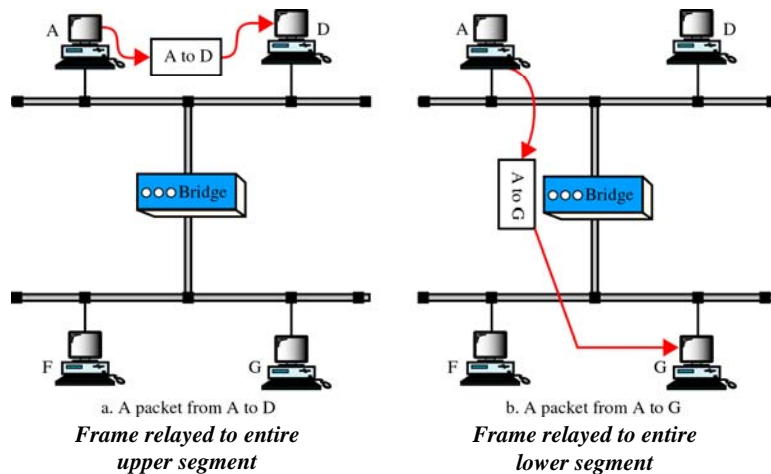

7

Internetworking Devices: Bridge types

- simple bridge** – links 2 segments; node addresses entered manually in bridge table
- multi-port bridge** – connects more than 2 segments:

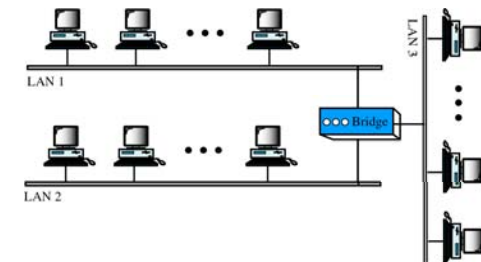

- transparent bridge** (also called a **learning bridge**) – builds its tables of addresses automatically as it relays Frames (by noting the source address in each Frame)
 - if more than one bridge connects 2 LANs, a loop could be formed in the bridges' forwarding tables ⇒ Frames could circulate forever
 - transparent bridges learn the topology and build a loop-free **spanning tree**
- source routing bridge** – each sender learns the topology (using *Discovery Frames*) and decides the **exact path** of segments and bridges each of its Frames will take

8

Internetworking Devices: Bridge between different LAN types

- example of a bridge connecting a CSMA/CD LAN to a Token Bus LAN:

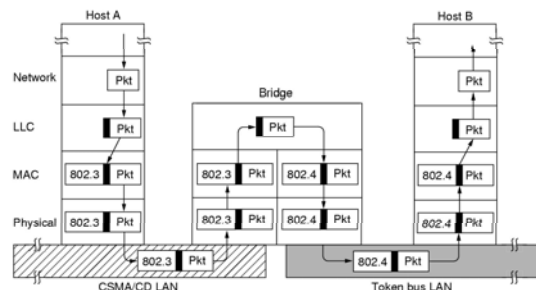

- problems in connecting different types of LAN:
 - different Frame formats
 - different payload sizes (e.g. 1500 bytes in Ethernet, 4500 bytes in Token Ring)
 - different data rates (e.g. 10 Mbps in Ethernet, 16 Mbps in Token Ring)
 - different bit order of addresses
 - presence or absence of priority bits
 - presence or absence of ACK/NAK

9

Internetworking Devices: Router

- a router operates in the Network, Datalink, and Physical layers
 - a router knows Network layer (“logical”) addresses

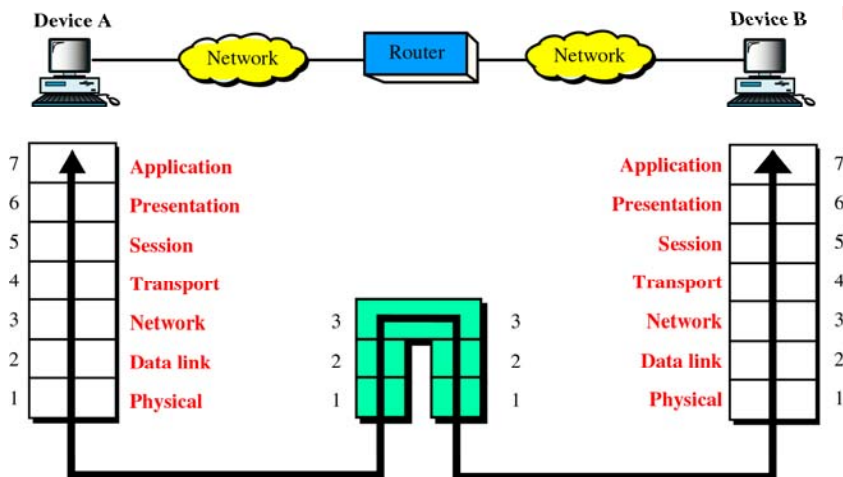

10

Internetworking Devices: Router (cont.)

- routers relay Packets among interconnected networks

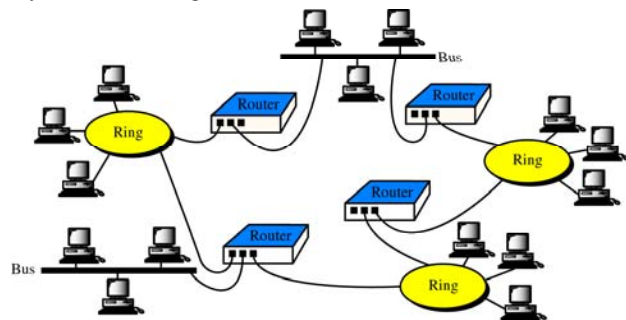

- a router has links to 2 or more networks at the same time
 - a router link to one of its connected networks has an address on that network
- if there is no router connected to both the sender’s network and receiver’s network, the router connected to the sender’s network transfers the Packet across one of its connected networks to another router which (hopefully) is “nearer” the receiver
 - Packets forwarded from one router to the next like this, until receiver is found

11

Internetworking Devices: Multiprotocol Router

- can relay Packets from 2 or more Network layer protocols

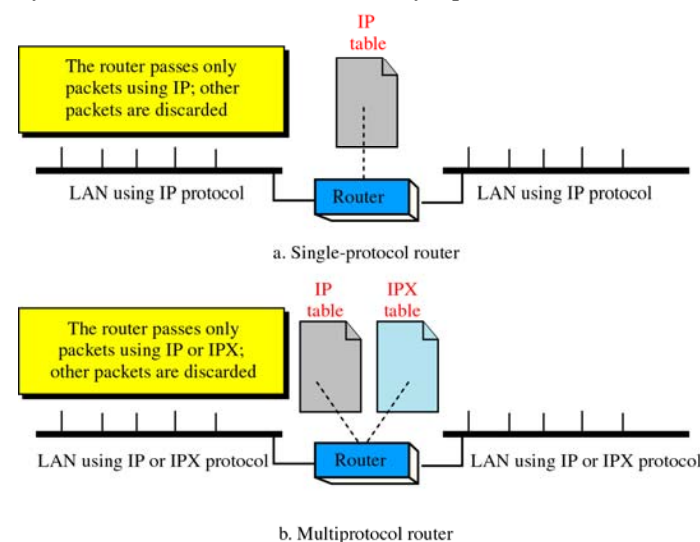

12

Internetworking Devices: Gateway

- also called a Protocol Converter
 - may have to operate in all 7 layers of the OSI Model

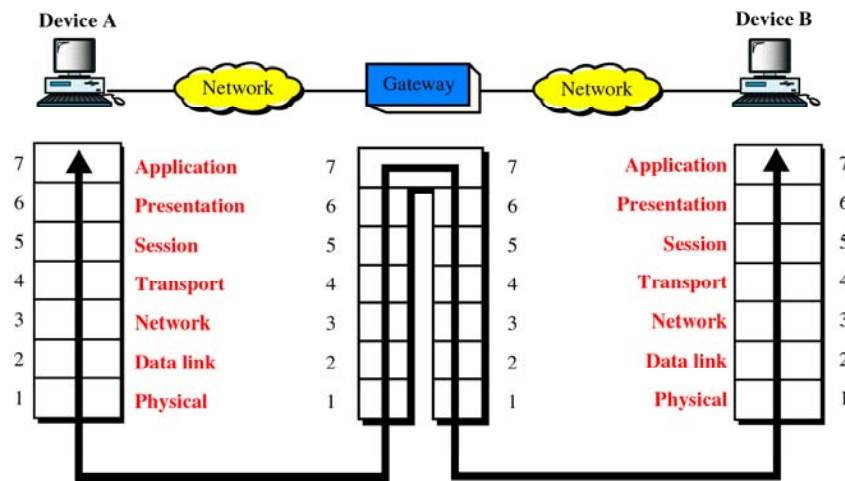

13

Internetworking Devices: Gateway (cont.)

- a gateway is usually a piece of software installed in a router
 - gateway software understands all the protocols used by networks to which the router is connected \Rightarrow can translate from one to another

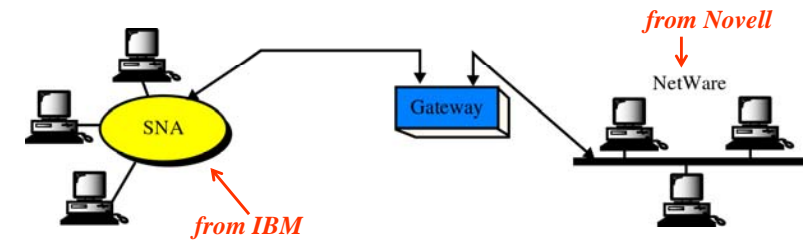

- adjustments to incoming packets could include changes to:
 - values in header and/or trailer fields
 - data rate
 - size of packet
 - entire format of packet

14